

Advancing the Future through Innovation



Business Idea

Our Ideology

We love our customers

We're loved by our customers

Always be a Virtuous merchant

Virtue as a merchant

It is important for us to have Virtue as a merchant in order to secure our customers' approval and support at all times.

Message by SANSHIN GROUP C.E.O.

We continue to progress as a "Going Concern with Others".

From our beginning as Sanshin Electric Co.,Ltd., in Tokyo, Japan in 1978, SANSHIN GROUP has steadily developed our business as a supplier of electronic parts in the electric industry.

Building long-term partnerships with our stakeholders, we formed SANSHIN GROUP, and created an internal development department at Sanshin Electric Co., Ltd. for custom-made power supply units with low-noise and high-performance. In 2001, Sanshin HK Co.,Ltd. was established in Hong Kong as our Asian hub. SHIN KOWA Co.,Ltd. was created in 2002, as a maker of superior Xenon lamps. SC2 Co.,Ltd., a business software design company, was established in 2004, and Sinfonie Electronics Co.,Ltd., maker of special inductors, was formed in 2006.

Through the synergy of three functions - a specialty trading company of electronic parts, a design department of custom-made power supply units with low-noise and high-performance, and a maker of creative electronic parts - we embody the mission of SANSHIN GROUP, which is the improvement of customer satisfaction and profitable growth and development. That is our "Going Concern with Others".



SANSHIN GROUP C.E.O.

PhD(B.A.) 石井 宏宗
Hiromune ISHII

Balanced Score Card

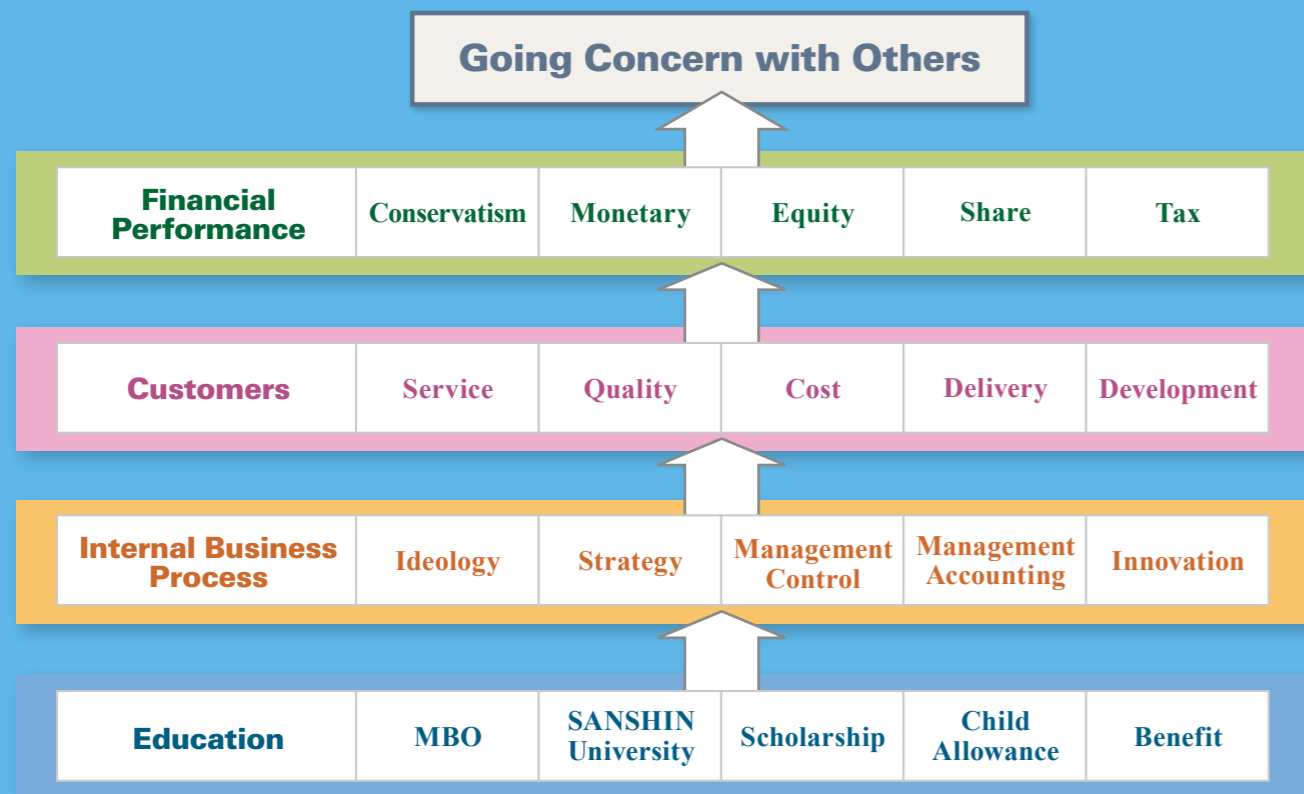

Our Standard Procedure

* Legal Compliance

- We create our quality control policy systematically, using a quality management manual based on the ISO9000 series standards.

* Contribution to Society and Electric Industry

- In accordance with environmental standards ISO14001 and ECO STAGE, we contribute to the electric industry and society through our advanced technologies.



ISO14001



- We work actively within an academic-industrial framework.
- We take pride in our surroundings and regularly clean the area around each of our office buildings.
- We decorate our lobby with seasonal displays, helping to make the neighbourhood warm and attractive.
- We welcome internship students from universities and technical colleges.
- Every year, we donate the Asahi newspaper to neighbourhood schools.

Core Competence

Four Keys Factors

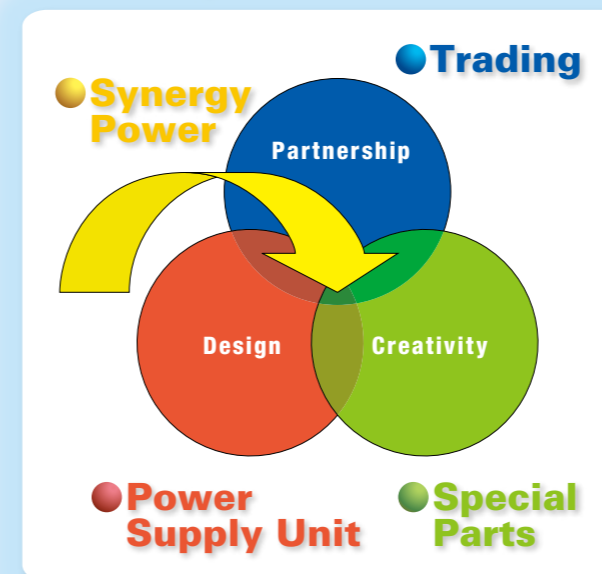

We continue to supply Creativity and Valuable Service !

Management Control Systems

Strategy implemented System : SiS



SANSHIN Thinking

We constantly strive for
"Accurate Knowledge"
↓
"Calm Judgement"
↓
"Courageous Action"
through the SANSHIN THINKING METHOD.

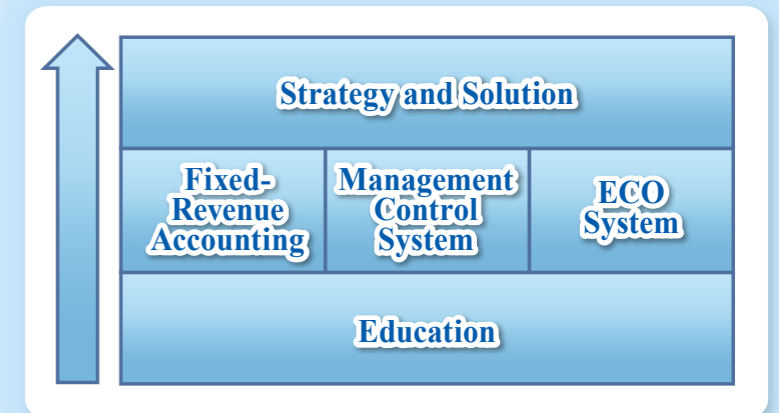

©Ishii_2014

Responsibility Centre and Project

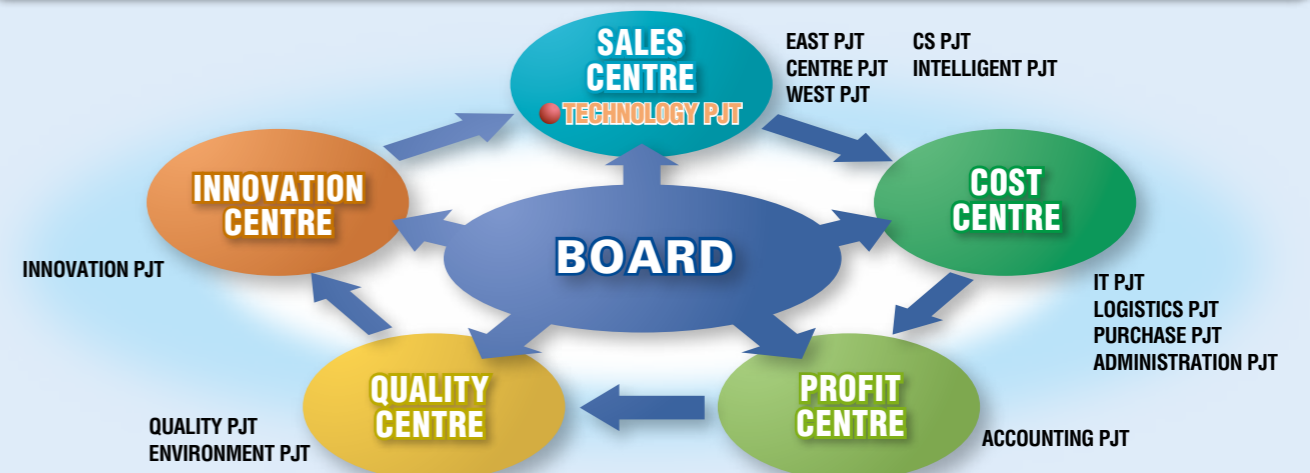

Advancing the future through Innovation!

SANSHIN

- Trading (Tokyo•Osaka•Nagoya•Kyushu)
- Power Supply Unit (Tokyo)
- Quality Management (Tokyo)
- Logistics (Tokyo)



DESIGN

QUALITY

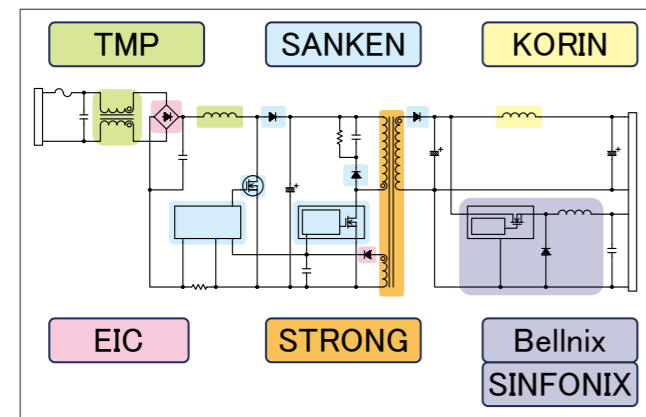

- * Trade of Electric products; mainly of Sanken Electric Co.,Ltd.
- * Design & Development of Analog Electric Circuits

Web : <http://www.sanshin-ele.com/sanshin/>

SANSHIN HK

- Trading (Hong Kong•New Delhi, India)

- * Overseas trading hub for all SANSHIN GROUP products

Web : <http://www.sanshin-ele.com/hk/>

SANKEN

A'SSY & TRADING

SINFONIX

- Special Coils (Tokyo)

- * Development and Sales of Inductor products
- * Development and Sales of MHIC
- * Development and Sales of Unit products applying proper unique parts

Web : <http://www.sanshin-ele.com/sinfonix/>

ORIGINAL PARTS



Metal-Composite Inductor



Spherical Transformer



Keiso-kohan

SHIN KOWA

- Flash Lamps (Chiba)

- * Development and Production of Xenon lamp
- * Development and Sales of LED lamp and LED illumination

Web : <http://www.sanshin-ele.com/kowa/>



Xe Tube

CSI (CEBU SHIN KOWA)

- Factory (Cebu, Philippines)

- * Production of Xenon Lamp
- * Production of Coil

SANKEN



Power Supply

Bellnix



Power Supply

TMP



Toroidal Coil

Business Line

SANSHIN GROUP

SANSHIN

- Trading (Tokyo•Osaka•Nagoya•Kyushu)
- Power Supply Unit (Tokyo)
- Quality Management (Tokyo)
- Logistics (Tokyo)

SANSHIN HK

- Trading (Hong Kong)
- Trading (New Delhi, India)

CSI (CEBU SHIN KOWA)

- Factory (Cebu, Philippines)

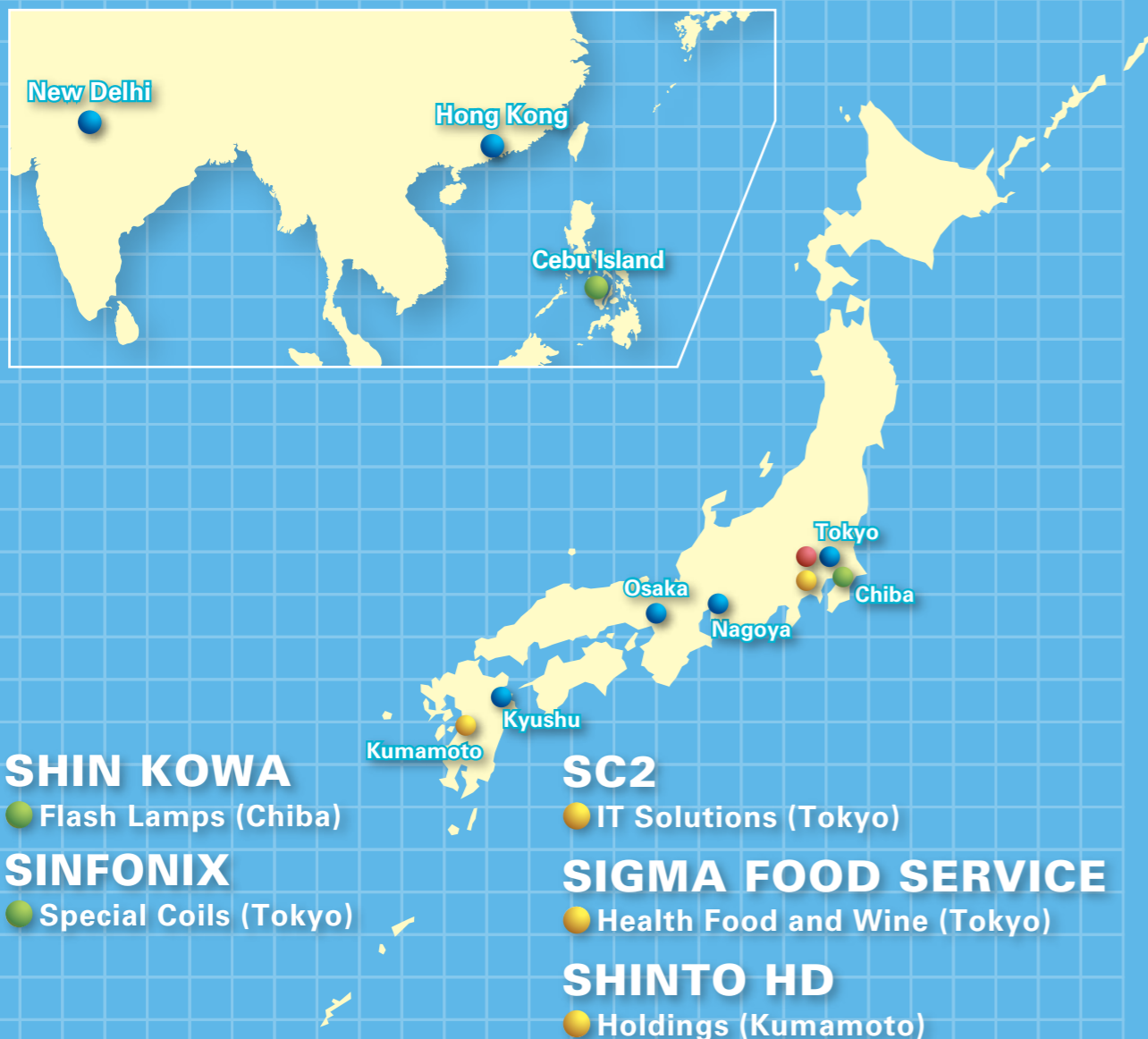

SHIN KOWA
● Flash Lamps (Chiba)

SINFONIX
● Special Coils (Tokyo)

SC2
● IT Solutions (Tokyo)

SIGMA FOOD SERVICE
● Health Food and Wine (Tokyo)

SHINTO HD
● Holdings (Kumamoto)

SANSHIN GROUP



SANSHIN

Web : <http://www.sanshin-ele.com/sanshin/>

サンシン電気株式会社

- 本社: 〒176-0022 東京都練馬区向山4-1-5 tel 03-5987-5511 (代表) tel 03-5987-5513 (営業部門ダイヤルイン)
- 関西営業所: 〒532-0011 大阪府大阪市淀川区西中島3-9-12 空研ビル10階 tel 06-6302-1781
- 名古屋営業所: 〒460-0002 愛知県名古屋市中区丸の内2-14-4 エグゼルの内ビル9階 tel 052-209-5411
- 九州事務所: 〒870-0848 大分県大分市賀来北1-16-21 サニーハレス賀来109号 tel 097-578-8236



SANSHIN HK

Web : <http://www.sanshin-ele.com/hk/>

三新電気香港有限公司

- 本社: RM602, 6/F., Winning Centre, 29 Tai Yau St., San Po Kong, Kowloon, Hong Kong tel +85-2-2321-6869
- インド ニューデリー: Room 960, Level 9, Spaze i-Tech Park A1 Tower, Sector-49 Sohna Road, Gurgaon 122018 INDIA tel +91-124-6768644

SHIN KOWA

Web : <http://www.sanshin-ele.com/kowa/>

新光株式会社

- 本社 (朝日工場・R&Dセンター): 〒289-1101 千葉県八街市朝日484番地 tel 043-235-8121
- 営業窓口: サンシン電気株式会社 Sales Centre, East PJT tel 03-5987-5513

CSI

CEBU SHIN KOWA, INC.

- 本社: 3rd St., Mactan Economic Zone 1, Ibo, Lapu-Lapu City 6015, Cebu, Philippines tel +63-32-260-6594



SINFONIX

Web : <http://www.sanshin-ele.com/sinfonix/>

シンフォニーエレクトロニクス株式会社

SC2

Web : <http://www.sanshin-ele.com/sc2/>

株式会社エスシーツー

- 営業所: 〒176-0022 東京都練馬区向山4-1-5 tel 03-3970-3651
- 業務内容:
 - 経営コンサルティング業務
 - 特許権等の知的財産権の取得、譲渡、管理およびコンサルティング業務
 - 人材育成のための教育事業ならびに講演会および研修会の企画および運営
 - コンピュータシステムおよびソフトウェアの設計、開発、制作、販売および輸出入業
 - 出版業
 - 人材紹介業
 - 人材派遣業

● IT solutions (Tokyo)

- * Management Consulting
- * Intellectual property and patent right consulting (including acquisition, assignment, and administration)
- * Human resource development and education (organize and operate lectures, seminars, and training workshops)
- * IT Solutions (design, development, production, and sales of computer and software systems)
- * Publishing
- * Recruiting
- * Temporary help business

多通貨販売管理システム / FRA



SF2

Web : <http://happy-go-lucky.webcluster.jp/>

株式会社シグマフードサービス

- 業務内容:
 - 一般酒類小売業、酒類の輸出入業
 - 厨房用什器販売業
 - 食品卸売業、食品のコンサルタント業、飲食業
 - 健康促進に関する商品の販売業
 - カウンセリング業
 - 動物取扱業(訓練)

● Health Food and Wine (Tokyo)

- * Sales of alcohol (primarily Japanese wine and sake)
- * Wholesale food business
- * Food business consulting
- * Catering trade
- * Sales of health-promoting products
- * Counseling business
- * Animal handling business (training)



SHINTO HD

Web : <http://www.sanshin-ele.com/shinto/>

新東ホールディングス株式会社

- 業務内容:
 - サンシングループ各社の経営管理業務等

● Holdings (Kumamoto)

- * Management of SANSHIN GROUP Companies



<http://www.sanshin-ele.com/>



SANSHIN GROUP

サンシングループ製品のお問い合わせは上記ホームページまたはお近くのサンシングループ各社までどうぞ。

Please contact us about our products and services at our homepage or to SANSHIN GROUP companies in your region.



FRA(JPN.Ver.)



FRA(ENG.Ver.)